



# Automated Fish Feeder Using Scheduler Mobile Application

Varry Alampayan Morial <sup>a\*</sup>

<sup>a</sup> Rymorj Computer Shop, Tolingon Mainit, Surigao del Norte, Philippines.

## Author's contribution

The sole author designed, analyzed, interpreted and prepared the manuscript.

## Article Information

DOI: 10.9734/AIR/2024/v25i21028

## Open Peer Review History:

This journal follows the Advanced Open Peer Review policy. Identity of the Reviewers, Editor(s) and additional Reviewers, peer review comments, different versions of the manuscript, comments of the editors, etc are available here: <https://www.sdiarticle5.com/review-history/112580>

**Original Research Article**

**Received: 17/11/2023**

**Accepted: 25/01/2024**

**Published: 29/01/2024**

## ABSTRACT

Today's fish feeder technology is a device dedicated to reducing labor costs and creating a better feed dispensing system in local fish farming productions. In this study, a newly developed automated fish feeder using a mobile scheduler application is designed and implemented specifically for Milkfish (*Chanos Chanos*) production. The development consists of four phases; online research, system design, purchase of materials, and construction. Two types of testing were conducted to evaluate this technology, including a functionality test and a technology acceptance test. The functionality test of the technology was tested using experimental analysis, which uses simulation to test the functionality of the developed system. Seven (7) trials tested the automated fish feeder using the mobile scheduler application for seven days. The study shows that this device was consistent in dispensing 0.43 Kilograms of feeds for one feeding schedule and 0.86 Kg for two feeding schedules, based on the total kilograms put in the system. There were ten respondents that participated in the technology acceptance test. From this test, the mean score values for all items such as availability, aesthetics, and performance were found to be more than 3.7 (using a 5-point Likert scale), which means that the automated fish feeder using the mobile scheduler application is very acceptable according to the technology acceptance test. The developed automated fish feeder using the mobile scheduler application will help the farmers remotely feed fish without hassle and optimize the quantity of feeds for the milkfish.

\*Corresponding author: E-mail: [varry.a.morial@gmail.com](mailto:varry.a.morial@gmail.com); [varry.amor@gmail.com](mailto:varry.amor@gmail.com);

*Keywords: Wifi; GSM; smartphone; milkfish; fishpond.*

## 1. INTRODUCTION

In the Philippines, aquaculture has a long history. It encompasses a wide range of environments and agricultural operations [1]. The majority of the industry's output comes from seaweed farming, milkfish, tilapia, shrimp, carp, oysters, and mussels [2]. Aquaculture is critical for food security, employment, and foreign exchange revenues [3]. Commercial fishing is lagging behind aquaculture in terms of growth [4]. Unless new markets and technology are identified, the future development of Philippine aquaculture may not be sustainable.

A mobile application is a communications facility or program application that runs on mobile devices [5]. Mobile applications can also be used to access similar services on desktop PCs. A mobile device is referred to as an app, web app, or online app [6]. The number of people developing mobile apps is steadily increasing. Businesses must match consumer needs for real-time, straightforward ways to conduct transactions and obtain information in commerce, communications, finance, medical, and politics [7]. Today, mobile applications on smartphones are the most popular way for people and businesses to connect to the internet [8]. A successful organization must stay relevant and responsive to develop a mobile application that their customers, partners, and employees need [9].

The advantage of a mobile app is that it gives users full software or hardware system access to the device and allows them to monitor and control it [10]. It improves the user's experience, and there are minimal budget costs. Users can perform several functions conveniently and securely from their smartphones with a mobile app [11].

Local fish farmers' method of feeding fish is that they will hire someone every day to feed their fish, and it will cost a significant amount of their budget for that [12]. Some local fish farmers who do not have an adequate hiring budget will work alone and regularly visit their fish cages [13]. We have developed an intelligent fish feeder since the current problem with local fish farmers is still an issue when feeding fish. For it to fully operate, the mobile application comes in [14].

The proposed solution to the problem is to create an automatic fish feeder utilizing a mobile

scheduler application. This new and upgraded fish feeder has many additional features and capabilities to aid local fish growers significantly. The technology is easily adaptable to large-scale fish feeding operations in the open sea. It may be accessible via a smartphone app connected via wifi, providing fish farmers with a simple method of communication. As a result, the device solves the problem. Still, it also includes additional beneficial functions for both users and owners. The project's goal was to create a business idea system to solve the difficulty outlined before. Because the system's design and functions are indisputably unique, the intelligent fish feeder with a mobile application is a step towards a better future in technology. This proposed approach provides ease while also assisting in reducing work or human power and engagement.

## 2. REVIEW OF RELATED LITERATURE

In the initial phase of technological integration into aquaculture [15], which spans from the late 20th to the early 21st century [16], the focus was primarily on automating basic processes to enhance efficiency and reduce the manual labor associated with fish farming [17]. During this period, researchers and developers concentrated on creating simple automated feeding systems and basic environmental monitoring tools [18]. These early systems represented the first steps towards the automation of aquaculture practices [19]. They were somewhat limited in scope and functionality, constrained by the technological capabilities of the time [20]. This era was marked by innovations that laid the groundwork for more advanced developments in the field [21]. Key studies and projects from this period demonstrated the potential benefits of incorporating mechanized systems into fish farming, although these were often rudimentary compared to later advancements [22]. The exploration and implementation of these initial technologies set a crucial foundation, paving the way for future innovations and more sophisticated systems in aquaculture technology [23].

In the early to mid-21st century, the field of aquaculture technology witnessed significant advancements in automation and remote monitoring [24], largely influenced by the burgeoning Internet of Things (IoT) and enhanced mobile connectivity [25]. This period saw a marked evolution in the sophistication and capabilities of automated feeding systems [26],

with a notable shift towards incorporating sensors [27], real-time data analytics [28], and wireless communication technologies [29]. These enhancements not only improved the precision and reliability of automated fish feeders but also introduced the possibility of remote management and monitoring of aquaculture systems [30]. Researchers and developers during this era focused on integrating advanced technologies to facilitate more efficient and controlled fish farming practices. The use of IoT devices allowed for the collection and analysis of vast amounts of data related to fish behavior [31], feed consumption, and environmental conditions, enabling more informed decision-making [32]. Wireless technology, including Wi-Fi and cellular networks [33], played a crucial role in facilitating real-time communication between the systems and the farmers [34], allowing for remote adjustments and monitoring [35]. This period also saw an increased emphasis on sustainability and resource optimization [36], with studies highlighting the potential of automated systems to reduce waste and improve the overall health and growth of fish [37].

The advancements in this period represented a significant leap from the earlier, more basic systems, illustrating the rapid progress in technology and its application in aquaculture [38]. The developments in this phase laid the groundwork for more complex [39] and integrated systems, showcasing the potential of technology to transform traditional fish farming into a more modern, efficient, and sustainable practice [40]. In the most recent phase, spanning from the mid-21st century to the present [41], the integration of mobile applications into aquaculture technology has emerged as a pivotal development [42]. This era is characterized by the convergence of advanced automation systems with user-friendly mobile interfaces [43], significantly enhancing the flexibility and control of fish farming operations [44]. The introduction of mobile applications has revolutionized the way aquaculture systems are monitored [45] and managed, enabling real-time interaction and decision-making from virtually any location [46].

The cutting-edge research and innovations in this period have focused on harnessing the power of smartphones and tablets to control and monitor automated fish feeder systems [47]. These mobile applications offer a level of convenience and accessibility previously unattainable, allowing users to schedule feeding times, adjust quantities, and monitor system performance

through intuitive interfaces [48]. The integration of cloud computing and big data analytics with these mobile platforms has further advanced the capabilities of these systems [49], enabling the processing and analysis of large volumes of data for optimized decision-making [50]. This period also witnesses a growing emphasis on sustainability and environmental stewardship within aquaculture practices [51]. Mobile applications have facilitated the adoption of more sustainable practices by providing detailed insights into resource usage [52], environmental conditions, and fish health, allowing for more precise and eco-friendly management of aquaculture systems [53].

The advancements in this latest phase of technology integration represent a significant leap forward in aquaculture practices [54]. The mobile application-controlled fish feeder systems [55], like the one developed in the current study, exemplify the culmination of these technological advancements, offering a sophisticated, efficient, and environmentally conscious solution to modern fish farming challenges. The transition to such smart, connected systems marks a new era in aquaculture, where technology and convenience intersect to create more sustainable and productive farming practices.

## 2.1 Theoretical Framework

The optimal foraging theory (OFT) is a behavioral ecology model that predicts how an animal, such as a fish, would act while looking for food. Although collecting food provides nutrition to the animal, searching for and catching the food takes energy and time [56]. An animal chooses a foraging strategy that maximizes net energy while providing the most gain (power) to maximize fitness. OFT aids in predicting the most effective way for an animal to accomplish this aim [57].

Natural history is full of observational data on ingestion. Still, researchers have only recently started seeing feed intake as a technique for whom the efficacy can be maximized through natural selection [58]. A feeding strategy theory's primary goal is to figure out which behavioral and morphological complex is best for collecting food energy in each environment for a specific animal. As a result, the task is an optimization problem, and the user can trisect it like every other optimization problem. As a result, the job is an optimization problem, and the user can trisect it like any other optimization problem [59].

Before the twentieth century, studies of the composition of fish diets were first published. Milkfish are opportunistic generalists that eat everything in their habitat, including detritus, phytoplankton, zooplankton, filamentous algae, and artificial feed. Algae, detritus, diatoms, animal elements, plant matter, and sand particles make up the diet of juveniles in their natural environment [60]. Pellets are their first choice when milkfish juveniles are given supplementary feed, followed by detritus, diatoms, and filamentous algae. Diatoms, zooplankton (including fish eggs and larvae), algae, litter, and small quantities of sand particles are all eaten by adult milkfish [61].

Milkfish fry, juveniles, and adults are oligophagous substratum-feeders in shallow-water habitats, consuming the top layer of bottom sediments and the micro-and meiofauna [62]. They consume artificial feed whole in culture systems. Their response to feeding is fast, as they provide it on the water surface right away. Feeding takes place in the water column as well as at the bottom. They can be taught to eat artificial feed by making a sound or supplying it at a specific time and location.

## 2.2 Conceptual Framework

The following figure shows the input-process-output diagram of the project.

Fig. 1 starts with the input wherein the researchers determine the materials and equipment necessary to visualize the research project. As shown in figure 1, inputs include; a mobile app, power supply, Arduino, stepper motor, wifi device, GSM module, and blower. The primary power source of this project is the power supply that drives the expected project to run.

After visualizing, the researchers proceed to the process stage where the online research, system design, purchase of materials, construction and testing, and system evaluation occur. This stage is crucial because it involves complex calculations, money risk, and trial and error. Knowledge and expertise aren't enough to complete the project; patience, determination, and cooperation with co-researchers.

The product of this research project is the automated fish feeder using a mobile scheduler application, wifi device, and SMS using GSM. This efficient and user-friendly device was made to give convenience to the users. This device is designed to fit the consumer's needs, and the materials used are economically and environmentally friendly and affordable.

## 2.3 Objectives

The overall goal of this project is to design and create/construct an automated fish feeder that uses a mobile scheduler app to assist local fish farmers, cutting costs and removing the inconvenient and time-consuming traditional method of fish feeding. As a result, the researchers devised the following set of precise goals:

1. To design a mobile app as a control mechanism for fish feeding.
2. To develop and implement a system securing the user's connection using a smartphone and the device installed in the fish cage area.
3. To evaluate the system's performance and acceptability using the pre-establish parameters.
4. To determine the economic feasibility of the system.

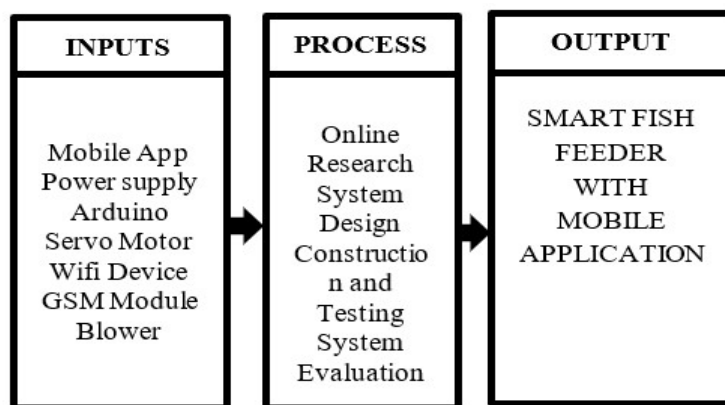

Fig. 1. IPO Diagram

### 3. METHODS

#### 3.1 Research Design

The "Experimental Design" method allows researchers to keep a tight grip on all variables that could influence the outcome of an experiment. The researchers are attempting to assess or predict what could happen. Experimental research designs aid the ability to limit possible theories and conclude direct causal interactions in the sample. For single studies, this method offers the highest standard of proof.

#### 3.2 Project Design

The project's block diagram is depicted in the diagram.

Fig. 2 shows the block diagram of the project. The figure shows that the system is powered by an AC source directly attached to the power supply. It gives power to the microcontroller, servo motor, and blower. The central brain of the machine is the microcontroller, and it will do all the logic processing and computation. The Arduino only accepts a DC source, so a DC power supply is needed. Once the user sets feeding time using the designed mobile application connected to the wifi device, it will send a signal telling Arduino when the stepper motor moves, and the blower release the feeds. The GSM module is used to deliver brief text messages to signal various events (SMS). This project uses a GSM module to notify the owner whenever the feed tank is empty. The owner will then know that it needs to be refilled.

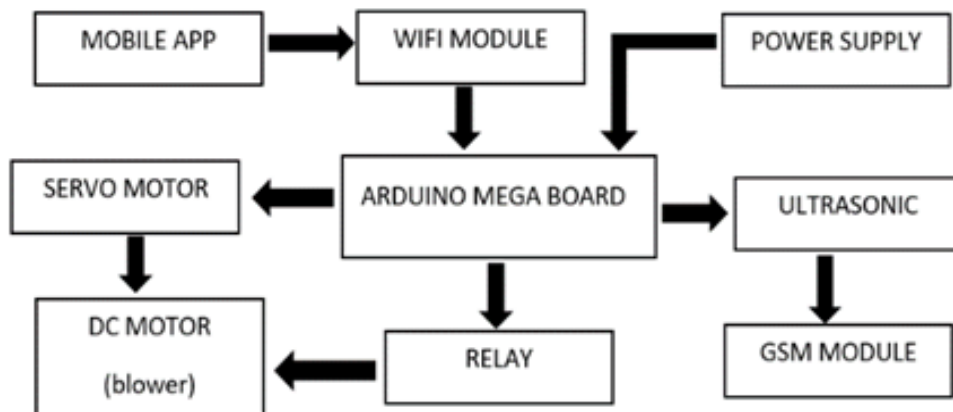

Fig. 2. Block diagram of the project

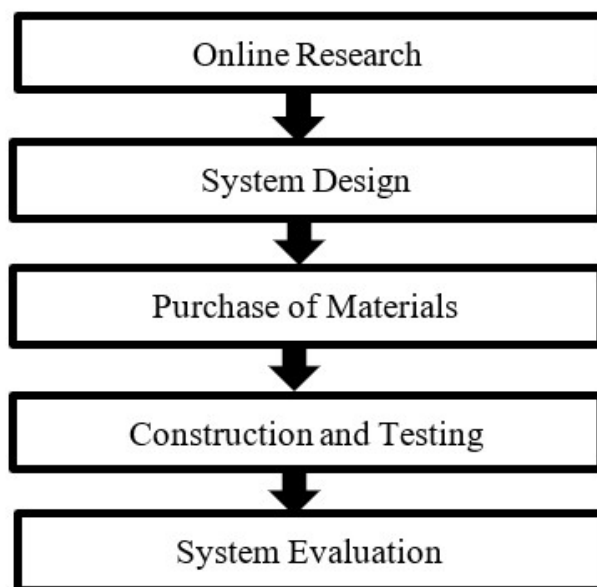

Fig. 3. Block Diagram of the project development

### 3.3 Project Development

The block diagram below shows the project development of the research.

Online researching or browsing the internet is the first stage of this project study. Almost everything a person wants to learn or needs to know in this generation is already on the internet. At this stage, the researchers can obtain some information and ideas that could assist them in executing a good project. System design is the next step in developing this project. Designing a system is an arduous task since the materials, finances, sizes, project mechanisms, packaging, and project settings should all be considered. All should be well prepared for in order to have fewer issues/casualties in the following implementation stage.

The procurement of materials is the third step. All materials should be ordered or ready for the project's construction as soon as possible. The next step is construction and testing. After purchasing the needed materials, the researchers can now start implementing the project. The internal parts, the solar panel, stepper motor, wifi device, GSM module, and some minor components such as connecting wires and others will be the first to be realized. Trial and error are often needed to verify whether the project is working correctly. Then, the project's packaging should be neat and presentable.

Finally, the last stage in this research project is system evaluation. The project will be evaluated based on its efficiency, performance, serviceability, aesthetics, and functionality. The researchers will conduct a survey using paper-

based techniques through questionnaires and personal interviews to hear the participants' opinions.

### 3.4 Project Implementation

The fully developed automated fish feeder using a mobile scheduler application is an electronic-based device designed to feed fish regularly. When the owner is away from the fishery area, this method is often used to minimize uncertainties and difficulties. This design aids in resolving some issues, including overfeeding and underfeeding, both of which result in fish starvation or even contamination of the fishery. Many subsystems make up the intelligent fish feeder system. It is made up of a feeder container used to store fish feed. It has a single outlet operated by a dc motor used to distribute food through a hole in the container. The users can also use the mobile app to customize the feeding time and feed volume according to the needs.

### 3.5 Project Setting

The project setting has been implemented in one of the fishponds near the coastline of Brgy. Sabang, Surigao City. It is near Makzterz Beach Resort, Sabang Surigao City.

### 2.6 Participants of the Study

The participants of this project study are mainly the local fish farmers residing in Brgy. Sabang, Surigao City, and representatives from BFAR (Bureau of Fisheries and Aquatic Resources). There are 10 participants, 8 for local fish farmers and 2 for BFAR representatives.



Fig. 4. Location of the place

### 3.7 Instruments

In this work, the following instruments below are used:

**Multimeter:** A VOM is a multi-function electronic measuring instrument. A conventional multimeter can measure voltage, current, and resistance.

**Arduino IDE Software:** The open-source Arduino Software makes writing code and uploading it to the board a breeze (IDE). Any Arduino board will work with this application.

**Proteus Simulator:** It's a software package that includes a schematic simulation and a PCB template. ISIS is an application that lets you build a circuit diagram and simulate it in real-time. Human involvement is possible during the simulation, allowing for real-time simulation.

**AutoCAD:** It is an Autodesk computer-aided drafting (CAD) software program that allows drafters, architects, engineers, and other professionals to build two-dimensional (2D) and three-dimensional (3D) mesh and solid surface models.

**Adobe Photoshop:** It's a well-known image-editing application. Photographers use it to alter images (color correction, noise removal, effects, and brightness/contrast adjustments).

**Mendeley:** It's a free reference manager that can help you organize your citations, collect references, and construct bibliographies. It's also a social network for academics that allows you to share your study with others. Researchers may participate in public or private online groups and scan the Mendeley community database of over 30 million papers for papers to read [19].

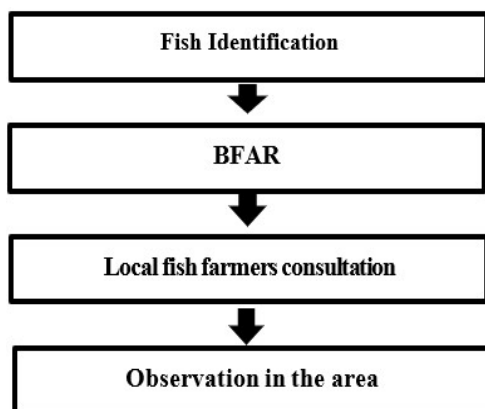

Fig. 5. Data collection procedure

### 2.9 Data Collection Procedure

The flow chart above shows the data collection procedure for this research project. These include web searching, trial & error testing, surveys/interviews, data gathering, and recording results. The first stage is web searching, wherein the researcher collects some information that could help them understand further about the project and how to make it work. Researchers focused on the issues and problems related to the study of interest to avoid errors in implementing the project. Conclusions and recommendations were also noted. A Series of trials and tests were conducted. The researchers gather data about the effectiveness of the project by conducting a survey, personal interviews, and providing some questionnaires to the participants. Researchers also recorded all data collected from survey questions and personal interviews.

Table 1. Participants of the Study

Participants	f(n=10)	% of Involvement
Fish farmers	8	80
BFAR	2	20
Representative/s		
Total	10	100

### 2.10 Statistical Tools

This project study uses mean standard deviation and frequency count as its statistical tool.

- A frequency count measures the number of times that an event occurs. It is usually used in the study to determine the number of participants involved in the study.
- The population's mean is calculated by combining all data points and dividing the sum by the number of issues. The formula is as follows:

$$\bar{x} = \frac{\sum x}{n}$$

- The standard deviation measures a set of values' variation or dispersion. The formula is stated below:

$$SD = \sqrt{\frac{\sum(x-\bar{x})^2}{n-1}}$$

## 4. RESULTS AND DISCUSSION

This section presents the output of the development of the automated fish feeder using

a mobile scheduler application in terms of the design of the mobile application, system implementation and hardware, system performance, system evaluation, and complete set-up.

#### 4.1 Design of the Mobile App

Fig. 6 represent the sequence of actions and decision-making processes within the mobile application developed for the automated fish feeder system and the detail the user's navigation through the app. It is a critical piece for understanding the app's interface, functionality, and the user's journey from setting up feeding schedules to receiving confirmations and alerts, thereby elucidating the integration of the mobile application with the physical hardware of the feeder system.

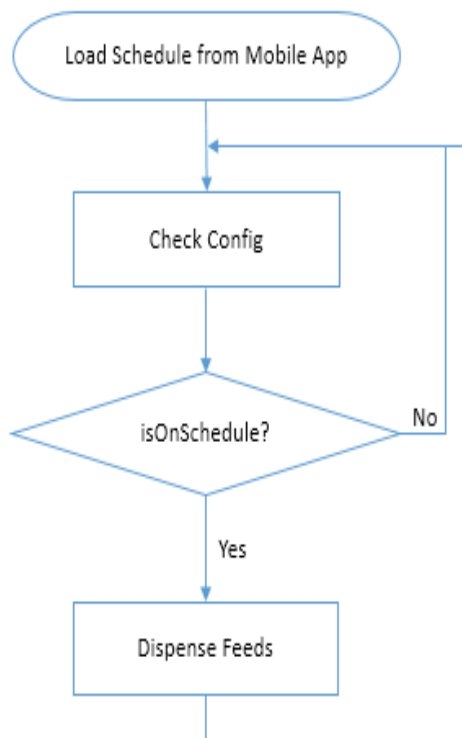

Fig. 6. Flow chart of the mobile app

Fig. 7 depicts the app's layout, the various controls available to the user, and how the user can interact with the system to set feeding schedules, monitor the status, and receive notifications. This figure would be instrumental in demonstrating how the mobile app serves as the interactive link between the user and the automated feeding system, providing a visual guide to the app's features and user experience.

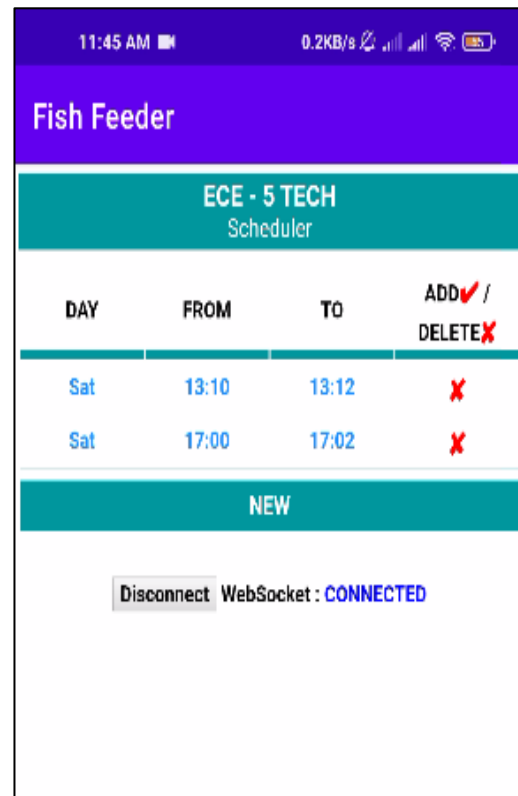

Fig. 7. The mobile app

#### 4.2 System Implementation of the Fish Feeder

This section shows the different hardware of the system, comprised of Arduino, Wifi Shield, Ultrasonic Sensor, Servomotor, DC Motor, Relay module, Arduino Mega, Arduino GSM Shield, and Schematic diagram.

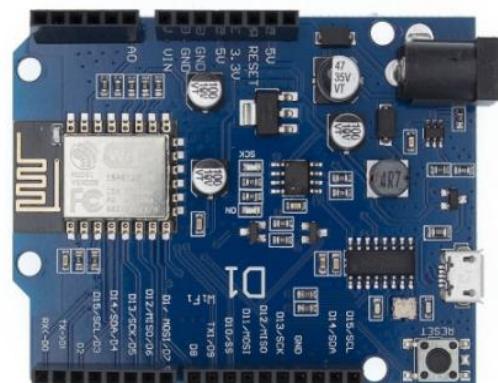

Fig. 8. Wifi Shield

The Arduino wifi shield connects an Arduino UNO board to the internet. It allows it to read and write data to an SD card using the wifi and SD



libraries. This component is crucial as it connects an Arduino UNO board to the internet. Its primary function is to enable the board to read and write data to an SD card using WiFi and SD libraries. This connectivity is essential for the automated fish feeder system as it allows for the transfer and management of data required for its operations.



**Fig. 9. Ultrasonic sensor**

An ultrasonic sensor is also an electronics device that uses ultrasonic sound waves to detect the distance between a target item that turns that reflecting sound into an electrical signal. This electronic device utilizes ultrasonic sound waves to detect the distance between itself and a target item. It functions by converting the reflected sound waves from the target into an electrical signal. This feature is particularly important in the automated fish feeder system as it helps in determining the appropriate positioning and movement for dispensing fish feed accurately.



**Fig. 10. Servo Motor**

A servomotor is a shut servomechanism that regulates its movement and end position through position information. A servo motor is a type of closed-loop servomechanism that controls its own movement and final position based on position feedback. This component is crucial in precision control tasks. In the context of the

automated fish feeder system, the servo motor likely plays a key role in controlling the mechanisms responsible for dispensing fish feed, ensuring accurate and controlled release of feed based on the programmed instructions.



**Fig. 11. DC Motor**

A DC motor is a rotating motor that converts electrical energy into mechanical energy. DC motors are a type of electric motor powered by direct current (DC) and are known for their high speed and torque capabilities. In the context of the automated fish feeder system, the DC motor likely plays a critical role in the mechanics of the feeding mechanism, such as moving parts that dispense the fish feed. Its operation ensures the efficient and controlled release of fish feed as programmed in the system.



**Fig. 12. Relay Module**

The relay module is a separate piece of hardware that allows you to control remote devices. A relay module is a separate piece of hardware that is used to control remote devices. In the context of the automated fish feeder system, this module likely plays a critical role in managing the operation of various components,

such as motors or sensors, allowing for the remote control and automation of the feeding process. It acts as an interface between the system's control unit and its mechanical components, facilitating the automated and programmable aspects of the fish feeder.

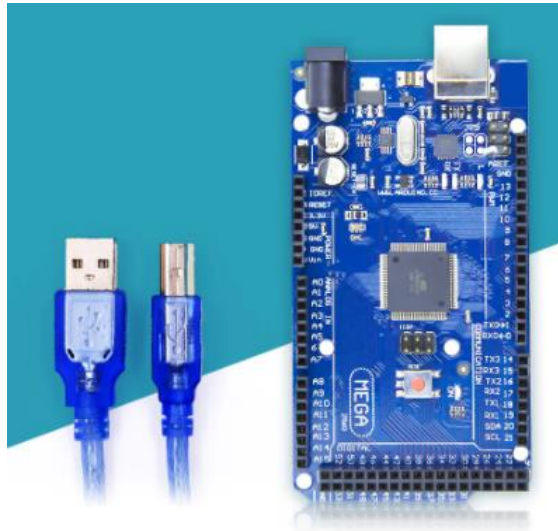

**Fig. 13. Arduino Mega**

The Arduino Mega is a microcontroller module based on the ATmega1280 (datasheet). The Arduino Mega is a microcontroller module that is based on the ATmega1280. It serves as a central processing unit for the automated fish feeder system, managing the inputs and outputs, and executing the programmed instructions. This component is crucial for integrating the various sensors, motors, and other hardware components, allowing for the coordinated and automated operation of the fish feeder.



**Fig. 14. GSM Shield**

The Arduino GSM shield uses the GSM library to connect an Arduino board to a network and send

and receive SMS. The Arduino GSM shield is utilized in conjunction with the GSM library to connect an Arduino board to a network. Its primary function is to send and receive SMS messages. This feature is particularly vital in the automated fish feeder system as it enables remote communication and control. Through this shield, users can receive updates and control the fish feeder system via SMS, adding a layer of convenience and flexibility to the management of fish feeding.

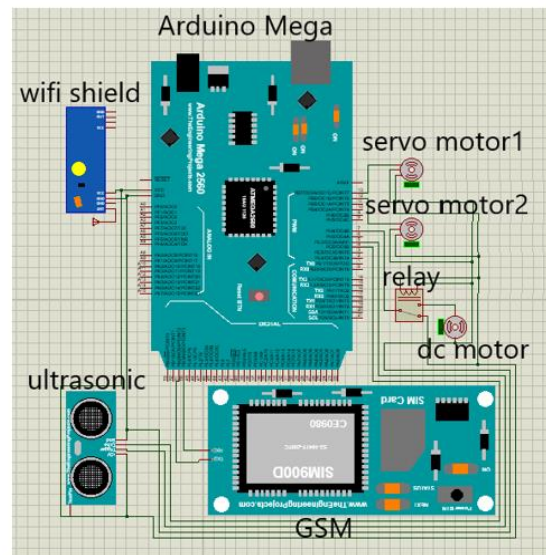

**Fig. 15. Schematic diagram**

The Schematic Diagram shows the wiring and different materials of the project. This diagram provides an overview of the wiring and various materials used in the project. Schematic diagrams are crucial in technical projects as they visually represent the connections and layout of an electrical system. In the case of your automated fish feeder system, this schematic would show how different components like the Arduino boards, sensors, motors, and other hardware are interconnected, providing a comprehensive guide for construction, troubleshooting, and understanding the system's operation.

### 4.3 System Performance Evaluation

The tables explain the seven-day simulation of the developed automated fish feeder using a mobile scheduler application. The researcher plotted the schedule using the application by simulating one and two feeding per day and checked the number of feeds if the system responded correctly. Based on the table, 0,83kg

were dispensed for two feeding schedules and only 0.43kg for one time feeding schedule by measuring manually the number of feeds retained in the fed tank. It shows consistently that the system works for the entire one week off schedule as shown only 3.55kgs was left in the tank for one-week test of the system.

**Table 2. Test result**

Number of Days # Of Trials	Measured Weight of Feds/Kilogram Total = 10 Kgs	Feeding Time Schedule (8:00 A.M., 1:00 P.M., 5:00 P.M.)		Number of Feeding/Day	Kilograms Per Day
		Feeds Dispense Between 1:00 P.M.-1:12PM	Feed Dispense Between 5:00 P.M.-5.12 P.M.		
DAY 1 (Trial 1)	9.14 Kgs	Feeds Dispense Between 1:00 P.M.-1:12PM	Feed Dispense Between 5:00 P.M.-5.12 P.M.	Two	0.86 Kgs
DAY 2 (Trial 2)	8.71 Kgs	None (Test w/o Dispensing)	Feed Dispense Between 7:00 A.M.-7:12 A.M.	One	0.43 Kgs
DAY 3 (Trial 3)	7.85 Kgs	Feed Dispense Between 11:00P.M.-11:12P.M.	None (Test w/o Dispensing)	One	0.43 Kgs
DAY 4 (Trial 4)	6.99 Kgs	None (Test w/o Dispensing)	Feed Dispense Between 1:00 P.M.-1:12 P.M.	One	0.43 Kgs
DAY 5 (Trial 5)	6.13 Kgs	Feed Dispense Between 3:00 P.M.-3:12 P.M.	None (Test w/o Dispensing)	One	0.43 Kgs
DAY 6 (Trial 6)	5.27 Kgs	None (Test w/o Dispensing)	Feed Dispense Between 7:00 A.M.-7:12 A.M.	One	0.43 Kgs
DAY 7 (Trial 7)	3.55	Feeds Dispense Between 1:00 P.M.-1:12PM	Feed Dispense Between 5:00 P.M.-5.12 P.M.	Two	0.86 Kgs

**Table 3. System performance acceptability survey**

CRITERIA	MEAN	STANDARD DEVIATION	QUALITATIVE DESCRIPTIVE
<b>A. In terms of System Availability</b>			
A Smart Automation on Dispensing Fish Feeds	3.8	0.422	Very Acceptable
A readily available Mobile App for accessing and controlling the whole system	3.9	0.333	Very Acceptable
A Wi-Fi based Connected Device	3.9	0.333	Very Acceptable
A Monitoring System through SMS Alert	3.8	0.422	Very Acceptable
TOTAL	3.85	0.376	<b>Very Acceptable</b>
<b>B. In terms of Aesthetics</b>			
System Packaging is presentable	3.4	0.667	Acceptable
Circuitry is well-designed	3.7	0.494	Very Acceptable
Neatness of Wiring Connection inside	3.7	0.494	Very Acceptable
TOTAL	3.6	0.552	<b>Very Acceptable</b>
<b>C. In terms of Performance</b>			
System Accuracy	3.7	0.494	Very Acceptable
System Durability	3.8	0.422	Very Acceptable
System automation	3.8	0.422	Very Acceptable
TOTAL	3.77	0.446	<b>Very Acceptable</b>
<b>D. In terms of features</b>			
Mobile App is readily available to access the Smart Fish feeder	3.9	0.333	Very Acceptable
System is Connected to a Wi-Fi to ensure the Maximum Range of Connectivity	3.8	0.422	Very Acceptable
Display of SMS alert in the Smartphone/Cellular phone	3.9	0.422	Very Acceptable
TOTAL	3.87	0.392	<b>Very Acceptable</b>
<b>GRAND TOTAL</b>	<b>3.77</b>	<b>0.442</b>	<b>Very Acceptable</b>

The "System Performance Acceptability Survey" table systematically evaluates various aspects of the automated fish feeder system, providing quantitative and qualitative data across four main categories. In terms of system availability, the system scores very well, indicating a robust and reliable performance for dispensing fish feeds, mobile application accessibility, Wi-Fi connectivity, and SMS alert functionality, with respondents rating these features as "Very Acceptable." Aesthetic considerations, such as packaging design and neatness of circuitry, received slightly lower but still positive ratings, ranging from "Acceptable" to "Very Acceptable."

Performance metrics such as system accuracy and durability also received high ratings, reflecting a strong approval of the system's operational capabilities. The features of the mobile app, including its range and connectivity, were similarly well-regarded, with the ability to connect to Wi-Fi and send SMS alerts being highlighted as particularly effective.

Overall, the aggregated mean score of 3.77 out of 5, with a standard deviation of 0.442, demonstrates a general consensus of the system being "Very Acceptable." This summary indicates that the system is well-received by its users, who appreciate its reliability, design, functionality, and technical features.



**Fig. 16. Actual Set-up of the project**

The Fig. 16 serves to demonstrate the practical implementation of the system, providing visual evidence of its design and how it functions within its operational environment. It is a crucial element for understanding the tangible aspects of the system's deployment and its interaction with the surrounding infrastructure.

## 5. CONCLUSION

Based on the comprehensive data collected and analyzed, the study confirms that the automated fish feeder system, integrated with a mobile

scheduler application, operates effectively and meets the anticipated outcomes. This innovative system enhances the existing technology in fish feeding by incorporating smart, user-friendly features that allow for precise control over feeding times through a smartphone interface. Not only does it streamline the feeding process, but it also introduces a high degree of efficiency and reliability at a relatively low cost. The empirical evidence, supported by the System Performance Acceptability Survey, demonstrates the system's robust performance and user satisfaction. Overall, the Smart Fish Feeder with Mobile App signifies a forward step in aquaculture technology, offering a cost-effective solution that promises to elevate the efficiency and sustainability of fish farming practices.

## CONSENT

As per international standards or university standards, respondents' written consent has been collected and preserved by the author(s).

## COMPETING INTERESTS

Author has declared that no competing interests exist.

## REFERENCES

1. Naylor R, Goldberg R, Primavera J, Nature NK. Undefined effect of aquaculture on world fish supplies, nature.com; 2000.
2. City I, Perspectives in aquaculture development in Southeast Asia and Japan: Proceedings of the Seminar on Aquaculture Development in Southeast. 1987;8-12,
3. The importance of fisheries and aquaculture to development.
4. Lester SE, Gentry RR, Kappel CV, White C, Gaines SD. Offshore aquaculture in the United States: Untapped potential in need of smart policy, Proc. Natl. Acad. Sci. U. S. A. 2018;115(28):7162-7165. DOI:10.1073/PNAS.1808737115/ASSET/65404163-FE62-4FF6-9B15-E3C60C11EC37/ASSETS/PNAS.1808737115.FP.PNG.
5. Islam R, Islam R. T. M.-I. J. of E., and undefined Mobile application and its global impact, Citeseer; 2010.
6. Bomhold CR. Educational use of smart phone technology: A survey of mobile phone application use by undergraduate university students, Program.

- 2013;47;4:424–436.  
DOI:10.1108/PROG-01-2013-0003/FULL/XML.
7. Demirkan H, Bess C, Spohrer J. A. R.-C. of, and undefined 2015, Innovations with smart service systems: analytics, big data, cognitive assistance, and the internet of everything, *aisel.aisnet.org*. 2015;37:35.  
DOI: 10.17705/1CAIS.03735.
  8. Pitt L, Parent M, Junglas I. A. C.-T. J. of S., and undefined, Integrating the smartphone into a sound environmental information systems strategy: Principles, practices and a research agenda, Elsevier; 2011.
  9. Buhalis D, Connor PO. Information communication technology revolutionizing tourism, *Tour. Recreat. Res.* 2005;30(3)7–16.  
DOI: 10.1080/02508281.2005.11081482
  10. Ylaya, Vrian. Experimental analysis using free space measurement for rapid and nondestructive moisture sensing in tropical almond fruit (*Terminalia Catappa* L.). *International Journal of Emerging Trends in Engineering Research*. 8. 2020;3546-3552.  
DOI: 10.30534/ijeter/2020/108872020
  11. Bauer L, Cranor LF, Reiter MK, Vaniea K. Lessons learned from the deployment of a smartphone-based access-control system, *ACM Int. Conf. Proceeding Ser.* 2007; 229:64–75.  
DOI: 10.1145/1280680.1280689
  12. Ylaya VJV, Malicay LG. Assessment of energy savings potentials at University in Lanao del Norte, Philippines; 2022.
  13. Ylaya V. School Level Information System (IS) Discontinuance Intention: A case study on Information System (IS) Discontinuance of Surigao State College of Technology SSCT. *Intelligent Information Management*. 2020;12:121-130.  
DOI: 10.4236/iim.2020.124009
  14. Wang C, Li Z, Wang T, Xu X, Zhang X, Li D. Intelligent fish farm—the future of aquaculture, *Aquac. Int.* 2021;29(6):2681–2711.  
DOI: 10.1007/S10499-021-00773-8
  15. Banhazi T, Lehr H, Black J. ... H. C.-... of A. and, and undefined, Precision livestock farming: an international review of scientific and commercial aspects, *abepublishing.org*; 2012.  
Available: <https://www.abepublishing.org/~abepubli/journals/index.php/ijabe/article/view/599> Accessed on: Jan. 24, 2024. [Online].
  16. Hang L, Ullah I, D. K.-C. and E. in Agriculture, and undefined. A secure fish farm platform based on blockchain for agriculture data integrity, Elsevier; 2020, Available: <https://www.sciencedirect.com/science/article/pii/S016816991932006X> Accessed on: Jan. 24, 2024. [Online].
  17. Gamboa, Gregorio & Morite, Analyn & Bacarro, Robert & Plando, Rowena & Ylaya, Vrian & Serna, John. (2023). Ricefield Health Monitoring System Using A Drone With Ai Interface. 2023:181-184.
  18. Chui M, Manyika J, Miremadi M. Where machines could replace humans-and where they can't (yet); 2016.  
Available: <http://dlh.jaipuria.ac.in:8080/jspui/bitstream/123456789/2951/1/Where-machines-could-replace-humans-and-where-they-cant-yet.pdf> Accessed: Jan. 24, 2024. [Online].
  19. Wolfert S, Ge L, Verdouw C. M. B.-A. systems, and undefined Big data in smart farming—a review, Elsevier; 2017.  
Available: <https://www.sciencedirect.com/science/article/pii/S0308521X16303754> Accessed on: Jan. 24, 2024. [Online].
  20. Pongcol, Daryl & Gerasta, Olga Joy & Macasero, Jesrey Martin & Ylaya, Vrian Jay & Pandian, Najie & Caberos, ai. Dual Continuous Wave Radar for Ground Object Detection in GNU-Radio with USRP. 2019;1-6.  
DOI:10.1109/HNICEM48295.2019.9073553.
  21. Boyd CE et al., Achieving sustainable aquaculture: Historical and current perspectives and future needs and challenges, *Wiley Online Libr.* 2020;51(3): 578–633.  
DOI: 10.1111/jwas.12714
  22. Brudeseth B, Wiulsrød R. ... B. F.-F. & shellfish, and undefined 2013, Status and future perspectives of vaccines for industrialised fin-fish farming, Elsevier.  
Available: <https://www.sciencedirect.com/science/article/pii/S1050464813005974>. Accessed: Jan. 24, 2024. [Online].
  23. Bregnballe J. A guide to recirculation aquaculture: An introduction to the new environmentally friendly and highly productive closed fish farming systems; 2022.
  24. Føre M, Frank K, Norton T. ... E. S., and undefined. Precision fish farming: A new framework to improve production in

- aquaculture, Elsevier; 2018,  
Available:<https://www.sciencedirect.com/science/article/pii/S1537511017304488>  
Accessed on: Jan. 24, 2024. [Online].
25. Edan Y, Han S, Kondo N. Automation in Agriculture, Springer Handb. Autom. 2009; 1095–1128.  
DOI: 10.1007/978-3-540-78831-7\_63
26. Ylaya VJV. School level is discontinuance intention: A case study on information system is discontinuance of Surigao State College Of Technology, Int. J. Phys. Soc. Sci. 2020;10(7):9–18.  
Available:<https://www.indianjournals.com/ijor.aspx?target=ijor:ijpss&volume=10&issue=7&article=002>  
Accessed: May 11, 2023. [Online].
27. Neethirajan SB. K.-S. and B.-S. Research, and undefined 2021, Digital livestock farming, Elsevier,  
Available:<https://www.sciencedirect.com/science/article/pii/S2214180421000131>  
Accessed: Jan. 24, 2024. [Online].
28. Ylaya, Vrian Jay. Power spectral density analysis of subsurface Electromagnetic Wave (EM) Radar Implemented in USRP 2932. International Journal of Advanced Trends in Computer Science and Engineering. 2020;9:4515-4520.  
DOI: 10.30534/ijatcse/2020/47942020
29. SN.- Sensors and undefined, Artificial intelligence and sensor technologies in dairy livestock export: Charting a digital transformation, mdpi. Coml; 2023.  
Available:<https://www.mdpi.com/1424-8220/23/16/7045>  
Accessed: Jan. 24, 2024. [Online].
30. Prakash C, Singh L, Gupta A, S. L.-S. and A. A, and undefined 2023, Advancements in smart farming: A comprehensive review of IoT, wireless communication, sensors, and hardware for agricultural automation, Elsevier.  
Available:<https://www.sciencedirect.com/science/article/pii/S0924424723004545>.  
Accessed: Jan. 24, 2024. [Online].
31. Rößmann M et al. Industry 4.0: The future of productivity and growth in manufacturing industries, inovasyon.org; 2015,  
Available:[https://inovasyon.org/images/Haberler/bcgperspectives\\_Industry40\\_2015.pdf](https://inovasyon.org/images/Haberler/bcgperspectives_Industry40_2015.pdf)  
Accessed: Jan. 24, 2024. [Online].
32. Arvanitis K. E. S.-T. O. A. Journal, and undefined Agriculture 4.0: the role of innovative smart technologies towards sustainable farm management, benthamopen.com; 2020.  
Available:<https://benthamopen.com/ABSTRACT/TOASJ-14-130/>  
Accessed: Jan. 24, 2024. [Online].
33. Chong C. S. K.-P. of the IEEE, and undefined. Sensor networks: evolution, opportunities, and challenges, ieeexplore. ieee.org; 2003  
Available:<https://ieeexplore.ieee.org/abstract/document/1219475/>  
Accessed: Jan. 24, 2024. [Online].
34. Halachmi I, Guarino M. J. B.-A. review of animal, and undefined. Smart animal agriculture: Application of real-time sensors to improve animal well-being and production, annualreviews.org; 2019.  
Available:<https://www.annualreviews.org/doi/abs/10.1146/annurev-animal-020518-114851>  
Accessed: Jan. 24, 2024. [Online].
35. Ylaya J. Improved Design of Binary Full Adder. International journal of advanced trends in computer science and engineering. 2020;9:4113-4116.  
DOI: 10.30534/ijatcse/2020/239932020.
36. Tedeschi L, P. G.-... of A. Science, and undefined 2021, Advancements in sensor technology and decision support intelligent tools to assist smart livestock farming, academic.oup.com. 2021;99(2):1–11.  
DOI: 10.1093/jas/skab038.
37. Halachmi I, Guarino M, Bewley J, Pastell M. Smart Animal Agriculture: Application of real-time sensors to improve animal well-being and production, Annu. Rev. Anim. Biosci. 2019;7:403–425.  
DOI: 10.1146/ANNUREV-ANIMAL-020518-114851.
38. Macasero, Jesrey Martin & Gerasta, Olga Joy & Pongcol, Daryl & Ylaya, Vrian Jay & Caberos, ai. Underground Target Objects Detection Simulation Using FMCW Radar with SDR Platform. 2018:1-7  
DOI:10.1109/HNICEM.2018.8666248.
39. Sodiq A, Baloch A, Khan S, N. S.-... of C. Production, and undefined. Towards modern sustainable cities: Review of sustainability principles and trends, Elsevier; 2019.  
Available:<https://www.sciencedirect.com/science/article/pii/S0959652619311837>  
Accessed: Jan. 24, 2024. [Online].
40. Kesavan P. ... M. S.-T. of the, and undefined. Strategies and models for agricultural sustainability in developing Asian countries; 2008. Royalsociety publishing.org.

- Available:<https://royalsocietypublishing.org/doi/abs/10.1098/rstb.2007.2189>  
Accessed: Jan. 24, 2024. [Online].
41. Ylaya, Vrian Jay, Gerasta, Olga Joy, Macasero, Jesrey Martin & Pongcol, Daryl & Pandian, Najie & Vicerra, Ryan. Linear Frequency Modulated Continuous Wave LFM-CW Short-Range Radar for Detecting Subsurface Water Content With Deep Learning. 2020:1-6.  
DOI:10.1109/HNICEM51456.2020.9400001.
  42. J. P.- Environment, development and sustainability, and undefined. Can sustainable agriculture feed Africa? New evidence on progress, processes and impacts, Springer; 1999.  
Available:<https://link.springer.com/article/10.1023/A:1010039224868>  
Accessed: Jan. 24, 2024. [Online].
  43. Ye X, Wang Z, Q.L.- Agriculture, ecosystems & environment, and undefined. The ecological agriculture movement in modern China, Elsevier; 2002.  
Available:<https://www.sciencedirect.com/science/article/pii/S0167880901002948>.  
Accessed: Jan. 24, 2024. [Online].
  44. Araújo SO, Peres RS, Barata J, Lidon F, Cochicho Ramalho J, Balafoutis T. Characterising the agriculture 4.0 landscape—emerging trends, challenges and opportunities, mdpi.com; 2021.  
DOI: 10.3390/agronomy11040667.
  45. Malik P, Sharma R, Singh R. ... A. G.-C., and undefined. Industrial Internet of Things and its applications in industry 4.0: State of the art, Elsevier; 2021,  
Available:<https://www.sciencedirect.com/science/article/pii/S0140366420319964>  
Accessed: Jan. 24, 2024. [Online].
  46. Pongcol, Daryl & Gerasta, Olga Joy & Macasero, Jesrey Martin & Ylaya, Vrian Jay & Caberos, ai. GNU-Radio Simulation Application for Impulse Radar Technique on Ground Object Detection. 2018:1-6.  
DOI: 10.1109/HNICEM.2018.8666440.
  47. V. Balaska, Z. Adamidou, Z. Vryzas, A. G.-Machines, and undefined. Sustainable crop protection via robotics and artificial intelligence solutions, mdpi.com; 2023.  
Available: <https://www.mdpi.com/2075-1702/11/8/774>.  
Accessed: Jan. 24, 2024. [Online].
  48. Hassoun A et al. Truths and myths about superfoods in the era of the COVID-19 pandemic, Crit. Rev. Food Sci. Nutr; 2022.  
DOI: 10.1080/10408398.2022.2106939.
  49. Ylay VJV, Bacarro RR. Novel rectenna design for RF harvesting. Engineering and Science. 2022;7(2):90-93.
  50. Delante VZ, Ylaya VJ, Vicerra RR, Bacarro RR. Energy potential of macopa irrigation using Pico-Hydro power plant design utilizing under-shot type waterwheel. In 2021 IEEE 13th International Conference on Humanoid, Nanotechnology, Information Technology, Communication and Control, Environment, and Management (HNICEM). 2021:1-6IEEE.
  51. Hassoun A, Harastani R. S. J.-... in F. S. and, and undefined. Truths and myths about superfoods in the era of the COVID-19 pandemic, Taylor Fr; 2022  
Available:  
<https://www.tandfonline.com/doi/abs/10.1080/10408398.2022.2106939>  
Accessed: Jan. 24, 2024. [Online].
  52. Sadique G. IoT based Smart Water Management, Water temperature, PH and Soil Moisture Monitoring System for Indoor Farming; 2023,  
Available:  
<http://dspace.iuc.ac.bd/xmlui/handle/123456789/7032>  
Accessed: Jan. 24, 2024. [Online].
  53. Hassoun A et al. The fourth industrial revolution in the food industry—Part I: Industry 4.0 technologies, Taylor Fr.  
Available:  
<https://www.tandfonline.com/doi/abs/10.1080/10408398.2022.2034735>  
Accessed: Jan. 24, 2024. [Online].
  54. Allioui H, Y. M.- Sensors, and undefined. Exploring the full potentials of IoT for better financial growth and stability: A comprehensive survey, mdpi.com; 2023.  
Available: <https://www.mdpi.com/1424-8220/23/19/8015>  
Accessed: Jan. 24, 2024. [Online].
  55. Kuru K. H. Y.-I. Access, and undefined. Transformation to advanced mechatronics systems within new industrial revolution: A novel framework in automation of everything (AoE), [ieeexplore.ieee.org](http://ieeexplore.ieee.org); 2019.  
Available:<https://ieeexplore.ieee.org/abstract/document/8675275/>  
Accessed on: Jan. 24, 2024. [Online].
  56. Ylaya VJV, Arcaya RC. A Review on non-evasive groundwater determination technique using Electromagnetic Wave Principle.

57. An animal chooses a foraging strategy that maximizes net energy while providing the most gain (power) to maximize fitness. OFT aids in predicting the most effective way for an animal to accomplish this aim - Google Search.
58. Ylaya VJV, Buba RT. Performance Analysis of Solar Powered Water Well Pump.
59. A feeding strategy theory's primary goal is to figure out which behavioral and morphological complex is best for collecting food energy in each environment for a specific animal. As a result, the task is an optimization problem, and the user can trisect i..
60. Calang XA, Al John ST, Gerasta OJL, Pandian N, Ylaya VJV. Low Cost High Frequency Tag Antenna for an Inventory Management RFID System. In 2019 IEEE 11th International Conference on Humanoid, Nanotechnology, Information Technology, Communication and Control, Environment, and Management (HNICEM). 2019:1-6. IEEE.
61. Lazard J. L. D.-F. and Aquaculture, and undefined. Freshwater aquaculture and polyculture, books.google.com; 2009.
62. Schückerl S, Sell AF, Kihara TC, Koeppen A, Kröncke I, Reiss H. Meiofauna as food source for small-sized demersal fish in the southern North Sea, Helgol. Mar. Res. 2013;67(2):203–218. DOI: 10.1007/S10152-012-0316-1/FIGURES/3

© 2024 Morial; This is an Open Access article distributed under the terms of the Creative Commons Attribution License (<http://creativecommons.org/licenses/by/4.0>), which permits unrestricted use, distribution, and reproduction in any medium, provided the original work is properly cited.

*Peer-review history:*  
*The peer review history for this paper can be accessed here:*  
<https://www.sdiarticle5.com/review-history/112580>